

K1EL – CPO

Code Practice Oscillator

Kit Assembly & User Guide



Revision A.3
April 9, 2020
www.k1el.com

Features

- Keyed sine wave oscillator with wave shaping
- Volume control
- Frequency (pitch) adjustment control approx. 400 Hz to 1800 Hz
- RTTY test tone generation mode (2125/2295 Hz)
- Pushbuttons allow easy keying and FSK for testing purposes
- Internal low volume speaker for quiet practicing
- 1/8" external speaker/headphone output jack with ½ watt output
- LED keying indicator lamp
- 1/8" stereo key input jack (Key/FSK)
- 1/8" audio line output jack adjustable 0 to 500 mV 5K impedance
- Mini-USB 5 volt power connector (power only, not data)
- Custom metal enclosure with stick on label

Description

The CPO is a versatile code practice oscillator with synthesized sine wave output and adjustable frequency and volume controls. A 1/8" input jack is provided to key the oscillator from practically any keyer or straight key. Note that the CPO does not have a built in keyer, it is only a tone oscillator. A single chip microcontroller provides all of the functionality of the CPO including sine wave generation. It is implemented in a Microchip PIC12F1501 single chip microcontroller. An LM386 provides a higher drive level for an internal speaker, external speaker, or headphones. A red keying pushbutton is provided to manually key the oscillator for testing purposes. When the frequency (pitch) control is set fully clockwise, RTTY test tone mode is enabled. When RTTY mode is active the tone frequency is fixed at 2295 Hz. Asserting the FSK input (or pressing the black pushbutton) will frequency shift the tone down to 2125 Hz.

Enclosure Label

Due to the extremely high cost of enclosure design and fabrication, we are changing the way we use them. In the past we would offer a custom enclosure with silkscreen for each product that we introduce. To continue this, we would have to double the price of our products. So going forward, we are designing one enclosure for multiple products and customizing them with a good quality stick-on product label. Following the trend in pro-audio gear, we place this label on top of the unit. This has an advantage in that you can see where rear connector plugs go without having to turn the unit around to look at the rear panel.

I am mentioning this here because we want to be up front with this new process and not surprise anyone.

CPO Functional Block Diagram

Figure 1 is a block diagram of the CPO. The CPO PIC accepts input from the pushbuttons and keying input jack. When keyed, the CPO generates a PWM encoded sine output that passes through a low pass filter and to both an audio line output connector and the input of the LM368 audio amplifier. The AF amp drives the external speaker output connector. When nothing plugged into the speaker connector, the amplified audio is switched the internal speaker. The Pitch control is read by an analog to digital converter in the PIC which governs the frequency of the audio tone generated. Power for the CPO is provided by a Mini USB connector, most any USB power supply can be used to power the CPO, which draws a small amount of current.

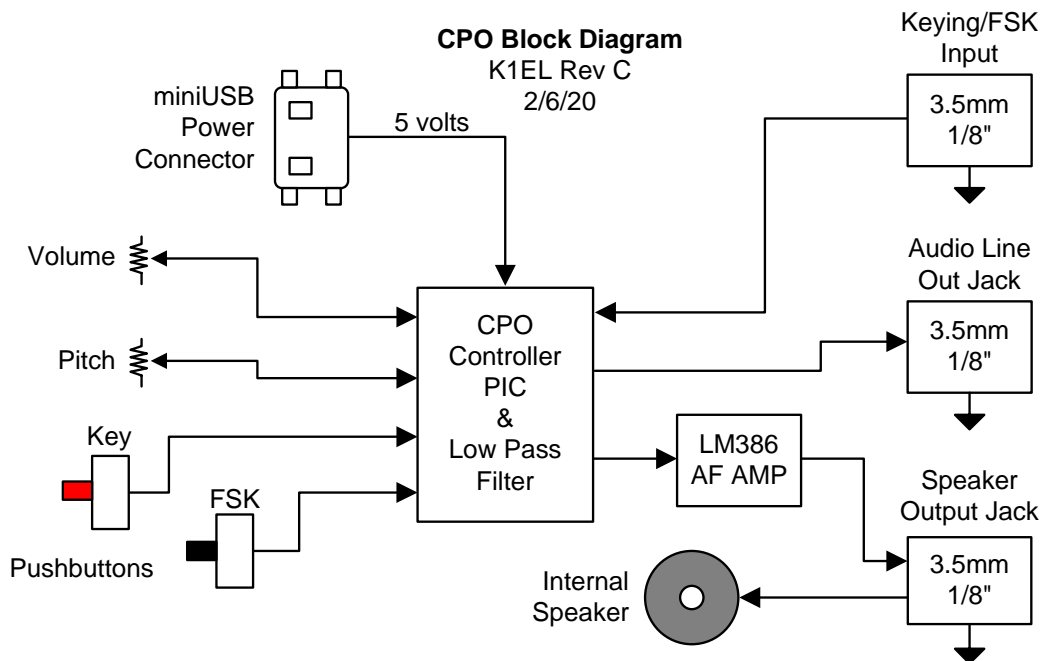

Figure 1 – CPO Block Diagram

CPO KIT Construction

The MTB keyer kit consists of a single board with all through-hole components for easy assembly. It's a good idea to read through all of the assembly instructions before starting. Please be sure to follow the steps in the order presented for best results. Even if you are an experienced builder, we highly recommend reviewing the appendices A, B, and C at the end of this document for helpful assembly hints. Bottom line, don't start assembly late at night when you are tired and in a hurry, it will just end badly.

Using the parts list as a guide, identify all of the components in the kit before starting. Check off each item in the list. If you are missing a part or are having trouble identifying something, email us and we will help: k1el.kitsinfo@gmail.com

CPO Parts List

Ck	Ref Des	Qty	Description
___	C1,C3,C4,C14	4	.01uF, ceramic capacitor (103)
___	C5,C8,C13	3	.0047uF ceramic capacitor (472)
___	C12	1	.047uF, ceramic capacitor (473)
___	C2,C7,C15,C16	4	.1uF, ceramic capacitor (blue) (104)
___	C10	1	1000uF,Capacitor Electrolytic
___	C6,C9	2	10uF,Capacitor Electrolytic
___	C11	1	100uF,Capacitor Electrolytic
___	R1	1	240 ohms 1/8W Red Yellow Brown
___	R8,R10	2	15K ohms 1/8W Brown Green Orange
___	R2,R3,R4,R5	4	10K ohms 1/8W Brown Black Orange
___	R9	1	12 ohms 1/8W Brown Red Black
___	RX2	1	5K Variable Trimmer Resistor (white)
___	D1	1	Red LED
___	S1	1	Black Push Button
___	S2	1	Red Push Button
___	U1	1	CPO PIC, PIC12F1501, 8 pin DIP
___	U2	1	LM386 8 pin DIP
___	SK1,SK2	2	8 pin DIP socket (for U1 and U2)
___	RX1,RX3	2	20K Potentiometer, right angle
___	J1,J4	2	1/8" SMT Jack
___	J2	1	1/8" SMT Jack w/switch
___	J3	1	Mini USB Jack, pre-soldered to PCB
___	SP1	1	Speaker
___	KN1, KN2	2	Control knob
___	PCB	1	CPO Printed Circuit Board
___	Enclosure	1	Metal Enclosure Top & Bottom
___	Feet	4	Press in rubber feet for enclosure base
___	Label	1	Product label 3.5" by 2"
___	HW1	5	4-40 x 3/16" silver pan head (pc board)
___	HW2	4	4-40 x 3/16" black pan head (cover)
___	DEPOPS		
___	R6	1	100 ohms 1/4W - Not Included

CPO Assembly Instructions

Figure 2 shows the CPO board as shipped, note that the Mini USB connector is pre-attached. The board is ready to build, please don't clean it with solvent or an abrasive pad. Be sure to use a good rosin core solder, avoid solder with acid or organic core.

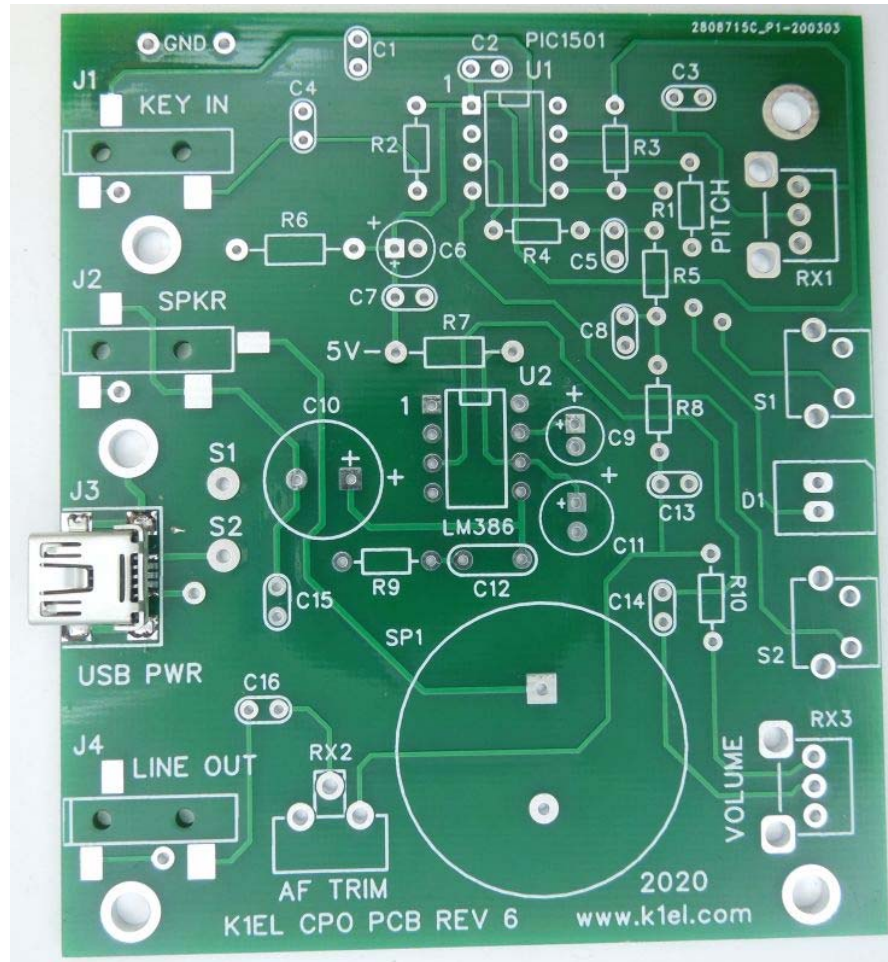

Figure 2 – Board as shipped from K1EL

Start assembly with the resistors, their color codes are presented in the parts list but feel free to verify them with an ohmmeter, the color bands on 1/8 watt resistors can be difficult to read. Use Figure 4 on page 6 as a guide. As with all components to follow, insert the component leads into the board and make sure the part is fully flush with the board. Then bend the leads to hold the part in place before soldering. Neatly trim the leads.

Using a resistor lead scrap, install a wire jumper at location R7. Leave R6 unpopulated.

Insert and solder the two 8 pin DIP sockets at locations U1 and U2.

Now add the following capacitors:

C1,C3,C4,C14 > .01uF C5,C8,C13 > .0047uF C2,C7,C16,C15 > .1uF C12 >.047uF

For a better fit, straighten out the .0047 uF capacitor leads as shown in figure 3 below.

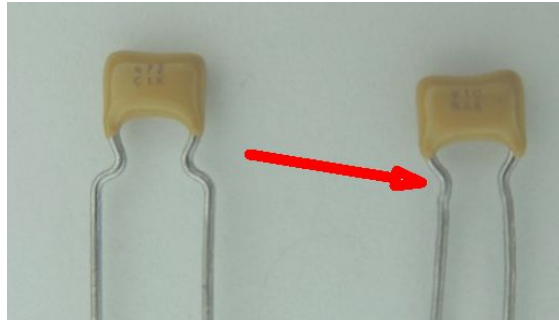

Figure 3 – C5, C8, C15 lead straightening

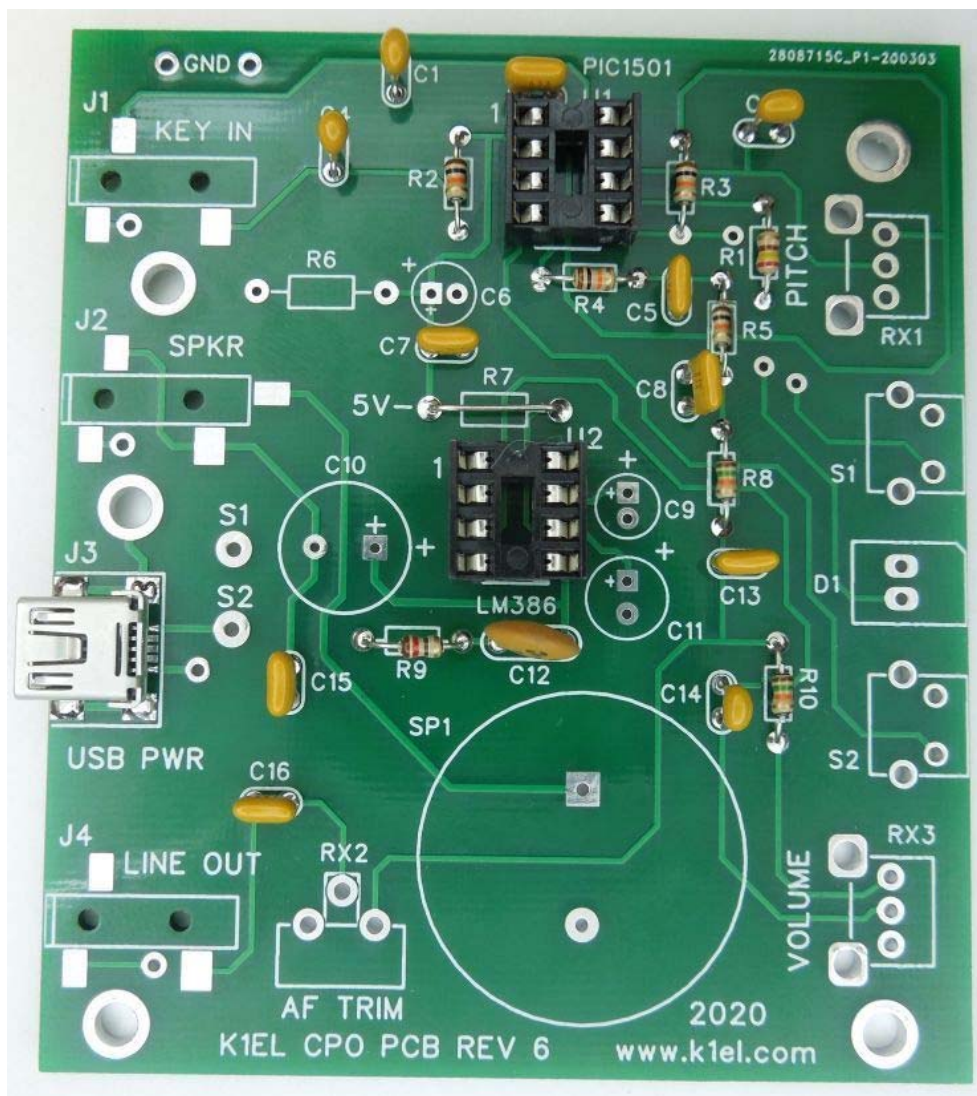

Figure 4 – First stage assembly complete

Bend the LED leads as shown in figure 8. Make sure you bend the leads correctly. Note that the flat side of the LED is facing away from the viewer. Populate the LED in the board so that the longer lead goes into the hole closest to S2. Do not solder yet.



Figure 8 – LED Lead Preparation

Our goal is to install the LED in such a way that it will just poke out of the enclosure front panel hole. It can't sit too high, too far front, or too far back. The following two pictures on page 10 illustrate the optimal LED placement.

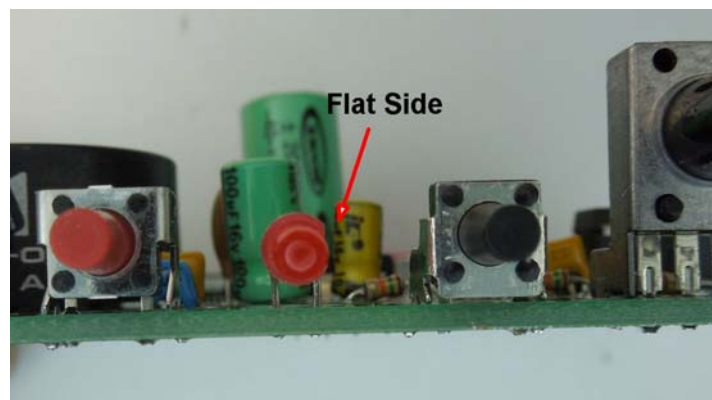

Figure 9 – The LED lines up vertically with the pushbuttons

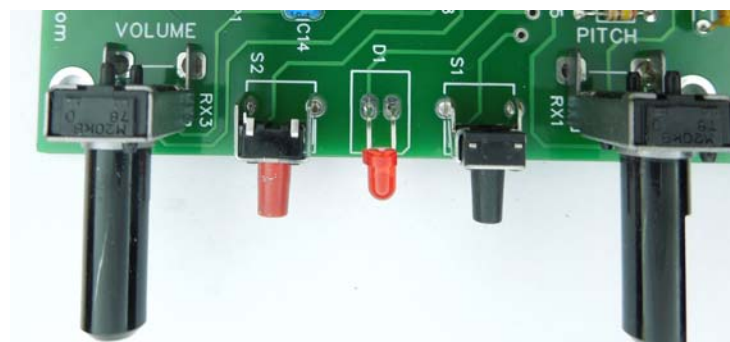

Figure 10 – The LED should extend from the PCB as shown

The CPO design has a provision for an on/off switch. It would be wired between PCB pads S1 and S2. Since the kit does not include a switch, S1 and S2 must be connected together with a resistor lead scrap as shown in figure 11 below. If desired, you can remove the jumper and add a switch later. Note that you would have to put a hole in the enclosure to add a power switch.



Figure 11 – DON'T FORGET TO JUMPER S1 to S2

Install the two 8 pin DIP ICs. The PIC12F1501 goes into position U1 and the LM386 goes into position U2. Please check to be sure you have pin 1 of the ICs in so that they are next to the number 1 on the silkscreen. Pin one is indicated by a small round dimple on the IC. The red arrows below point to pin 1 on each IC.

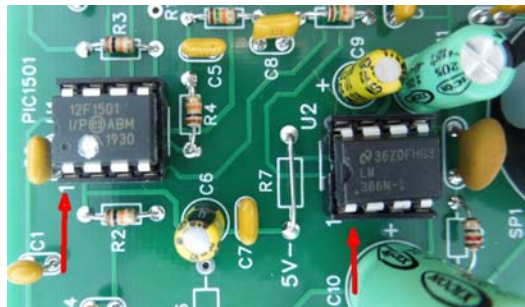

Figure 12 – U1 and U2 Pin 1 orientation

This concludes the assembly of the CPO board. With the exception of R6 should be no missing parts. Be sure that all parts have been soldered without missing solder connections or solder shorts.

CPO Kit Checkout

If you have a voltmeter get it out and get ready to measure voltage. Plug a USB cable into the CPO and plug the other end into a USB charger or USB power supply. Measure the voltage between the jumper at R7 and the ground pads next to J1. You should see something very close to 5 volts. Now set the volume and pitch controls to mid range. Press the red pushbutton and you should hear a tone from the built in speaker, it won't be super loud. You will also see the LED light up with the tone. Now adjust the pitch control while holding down the red button and you should hear the audio frequency change. If you advance the pitch control fully clockwise you will select RTTY test tone mode. Now when you press the red pushbutton you will hear a tone of approx 2125 Hz and if you press both pushbuttons the frequency will shift approximately 170 Hz.

If you have a set of stereo headphones, adjust the volume to minimum and then plug them into the external speaker jack. Press the red pushbutton and advance the audio level to a comfortable listening level. Note that the internal speaker will now be off. If you have an external speaker, you can test that the same as headphones. Note the speaker must have a stereo connector with the speaker connected between tip and ring.

The audio line output can be fed into an amplifier to generate even more volume. The CPO's internal trimmer can be adjusted to provide a convenient level.

Troubleshooting

The CPO is a fairly simple kit and if you take your time it should work the first time it's powered up. Here are a few areas to check out if you are having trouble.

If you don't see 5V, make sure the S1 to S2 jumper is in place. Is your USB power source working properly? Do you have a good USB cable? Are the electrolytic caps in correctly with black stripe away from the + sign?

If you have power but no tone, make sure that the two ICs are in the right place, positioned correctly, and without bent or missing pins. Is the speaker soldered in correctly? Is the jumper at R7 installed? Look for missed solder connections on the control pots or other components on the board. Is there output on the AF line out connector? If so that narrows it down to the AF amplifier section. Does external speaker connection work? If so, that means points to the internal speaker connections.

Finishing Touches

Now that everything is working, it's time to finish CPO assembly. Push on the volume and pitch control knobs. You will have to align the flat of the shaft with the flat of the knob. Now attach the top cover. The easiest way to do this is to fold the top in position using the USB connector as an anchor point. Once the connector lines up with its hole you can fold the top down easily. Attach the top with four black 4-40 screws (HW2).

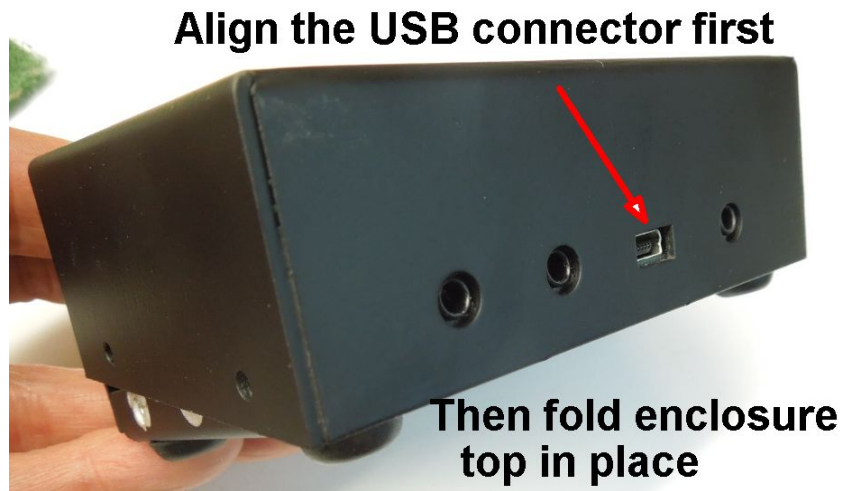

Figure 14 – How to attach top cover

Control Knob Positioning

You may find the control knob positioning unfamiliar. The following drawing illustrates how they work. In this example, the volume control is set to minimum while the pitch control is set to midrange.



Figure 15 – Volume and Pitch Settings

Using the CPO Kit

The CPO is strictly a tone generator, it does not have an internal keyer that automatically generates dits and dahs. Instead it will generate a tone for as long as the key input or red pushbutton is held on (low). The CPO has built in pull ups on both the key and FSK inputs so you can connect the CPO directly to the output of an open collector keyer (WKUSB, K44, K16 or similar) and it will work fine. It also works well with a straight key.

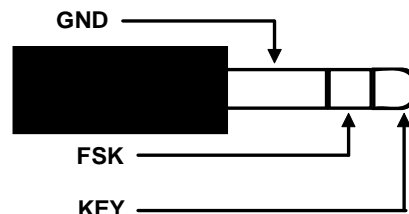

Figure 16 – CPO Key/FSK Input Connections

Note that the FSK input is only used when the CPO is in RTTY test tone mode which happens when the pitch control is adjusted fully clockwise. That is the only time the CPO will look at the FSK input. So in normal operating mode you can use a mono plug for the key input and it will key the CPO just fine.

Pushbutton hint: The pushbuttons can be activated two ways, either by pressing in on the button (which is rather difficult) or by pushing the button so that it tilts down.

The CPO will output a tone in three different ways:

Internal Speaker: is intended for practicing at a low volume level so as not to disturb others. The speaker's output varies with frequency so you will find some frequencies are much louder than others. The volume control will affect the internal speaker volume.

External Speaker/Headphones: A more flexible option is to use the external speaker connector. This can drive a set of stereo headphones or an external 4-16 ohm speaker. Note that the external speaker must be wired with a stereo connector as shown below:

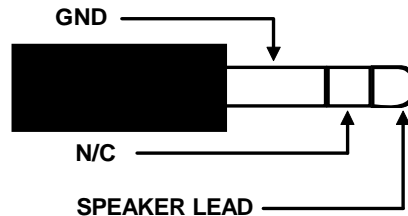
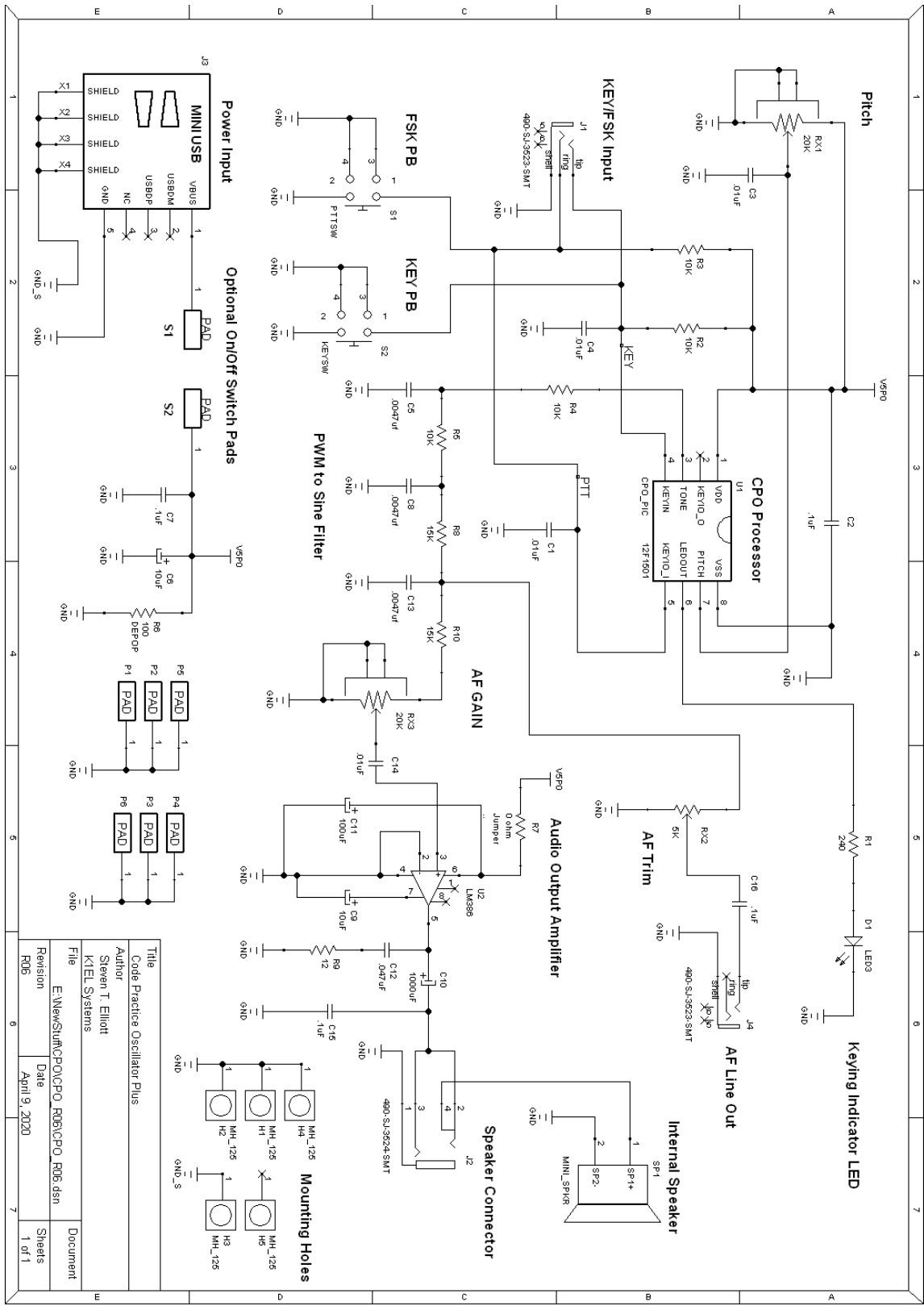

Figure 17 – CPO External Speaker Connections

Audio Line Out: The audio line out connector provides a high impedance (10K) output level that is adjustable by trimmer between 0 and .4 V RMS. This is a very useful for generating tones for remote CW operation or to feed a powerful audio amplifier to fill a room with Morse tones. A mono or stereo plug can be used for the line output connector.

CPO Schematics



A Word or Two Regarding USB Phone Charging Batteries

These are generally not suitable for use with the CPO. Most require a minimum current draw of about 100 mA, if this is not met, they will shut off automatically. Unfortunately this current level is far above the CPO idle current. What usually happens is the charger will run the CPO for about 5 minutes and then shut down. We have found some charging batteries that will provide power indefinitely but the majority won't. To get around this, a ballast resistor (R6) can be populated on the CPO board to boost the CPO current draw but this is not recommended because it wastes power, reduces battery life, and generates excess heat. Just say no....

Support and Warranty Information

The CPO is fully warranted to the original purchaser by K1EL Systems against defects in materials and workmanship for one year after purchase. This warranty does not cover damage caused by accident, improper assembly, or lightning damage. Please contact us before returning your CPO for repair and we will issue an RMA. Please submit questions by e-mail to k1el.kitsinfo@gmail.com

Watch our website for latest updates and new products: <http://www.k1el.com>

While every effort has been made to insure that the CPO design is as complete and safe as possible, it is still possible to cause equipment damage or incur personal injury if:

- 1) **The CPO kit is not used as intended.**
- 2) **Is connected incorrectly.**
- 3) **Safety guidelines outlined in this document are not followed.**
- 4) **The CPO kit is modified in any way.**

K1EL Systems LLC cannot be held responsible in these or other similar events

Revision History

CPO Data Sheet

- A.1 Initial release
- A.2 Several minor typo corrections
- A.3 Incorporated changes for Rev 6 PCB
 - a) Component change to make speaker audio gain range more linear
 - b) Increased Line Out level range
 - c) Rotated line out trimmer for easier access.

CPO PIC Firmware Revision

Rev A Original Release

Index

Features.....	2
Description.....	2
Enclosure Label.....	2
CPO Functional Block Diagram.....	3
Figure 1 – CPO Block Diagram.....	3
CPO KIT Construction.....	3
CPO Parts List.....	4
CPO Assembly Instructions.....	5
CPO Assembly Instructions.....	5
Figure 2 – Board as shipped from K1EL.....	5
Figure 3 – C5, C8, C15 lead straightening.....	6
Figure 4 – First stage assembly complete.....	6
Figure 5 – Second stage assembly complete.....	7
Figure 6 – Surface mount jack installation.....	8
Figure 7 – Third stage assembly complete.....	8
Figure 8 – LED Lead Preparation.....	9
Figure 9 – The LED lines up vertically with the pushbuttons.....	9
Figure 10 – The LED should extend from the PCB as shown.....	9
Figure 11 – DON'T FORGET TO JUMPER S1 to S2.....	10
Figure 12 – U1 and U2 Pin 1 orientation.....	10
Final Assembly.....	11
Figure 12 – Carefully align and attach top sticker.....	11
Figure 13 – Attach PCB to enclosure base with five screws.....	11
CPO Kit Checkout.....	12
Troubleshooting.....	12
Finishing Touches.....	12
Figure 14 – How to attach top cover.....	13
Control Knob Positioning.....	13
Figure 15 – Volume and Pitch Settings.....	13
Using the CPO Kit.....	13
Figure 16 – CPO Key/FSK Input Connections.....	13
Figure 17 – CPO External Speaker Connections.....	14
CPO Schematics.....	15
A Word or Two Regarding USB Phone Charging Batteries.....	16
Support and Warranty Information.....	16
Revision History.....	16
Index.....	17
Appendix A - Kit Construction Hints.....	18
Appendix B - A Note About Safety.....	19
Appendix C - Soldering Basics.....	19

Appendix A - Kit Construction Hints

1. Find a good workspace.

It is essential that you have a good place to work on your kit,

You will need room to spread out your parts and have access to tools. Good lighting and ventilation is essential. A magnifying glass or visor is highly recommended.

2. Have the proper tools.

At a bare minimum you will need:

Small side cutters, flush cutters are a plus.

Small needle nosed pliers

Small flat blade & Philips head screw drivers

A good quality, 40-60Watt, temperature controlled Soldering Iron. The price has come down on these lately, you can buy a Weller WLC100 40W soldering station with adjustable temperature control for \$40 on Amazon.

3. Read the Instructions First.

Read through the assembly instructions completely and have everything on hand before you start. Inventory the kit parts, make sure you have ALL of them.

4. Follow the assembly instructions in order.

Although not always obvious, the order in which parts are added to a board is important and should be followed. Sometimes sections are installed and tested in order or there could be a mechanical clearance consideration.

5. Keep your Workplace Clean and Orderly.

Nothing spoils a kit building experience more than lost parts. Second to that are stray bits of dirt and metal that get into a printed circuit board assembly. Our PC boards are nicely plated and accept solder easily. There is no need to clean the board with steel wool before starting. A good rosin core solder will work fine. Lead free solder is recommended for health reasons.

6. Take your time.

There is no need to rush, enjoy the process and the end result will be much better. Moving too quickly or working when you are tired often leads to big mistakes which could be difficult if not impossible to fix.

Appendix B - A Note About Safety

Burns to your skin can be very painful and can lead to serious injury.

Burns to your eyes can be catastrophic.

Toxic fumes can cause serious harm.

Flying objects such as wire ends etc. can cause painful and serious injuries.

When building your kit please remember that Soldering Irons and Solder are used at High Temperatures !

Soldering Irons can remain hot for many minutes after being turned off. Never touch the tip to see if it is hot. Touch the tip to a wet pad to test for temperature.

Wear safety glasses to protect your eyes from flying objects.

Appendix C - Soldering Basics

1. Insert component leads into PCB holes and bend them back slightly to hold the part in place. You can either trim the lead now or wait till after the joint is soldered. I usually install several parts at one time and then solder and trim multiple leads.
2. Place a hot and clean iron tip against both the lead and pad as in Fig. A1.

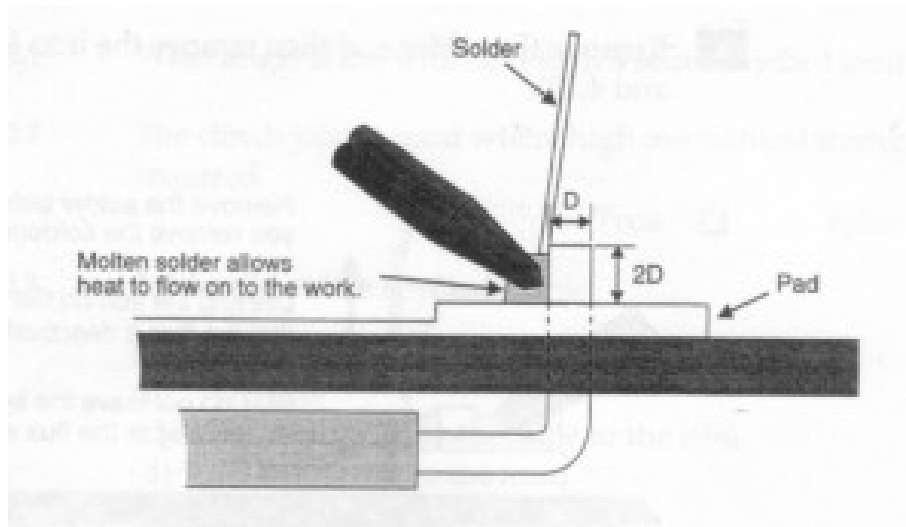

Figure C1 - Form a heat bridge

3. Create a heat bridge between the lead, the PCB pad and the iron by placing a small amount of solder on the tip.
4. Apply solder around the outside edge of the pad as in Fig. A2. If the pad and lead are at the correct temperature, the solder will flow around the connection.

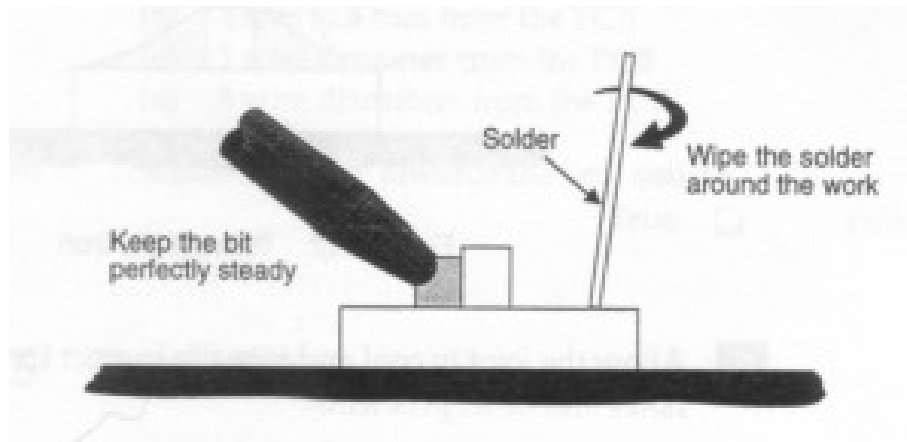

Figure C2 - Spread solder around the work

5. Remove the solder and then remove the iron.

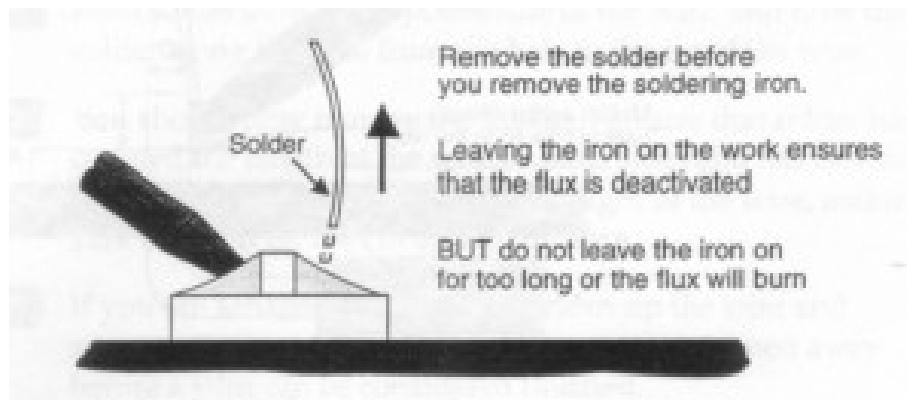

Figure C3 - Remove the solder

6. Allow the joint to cool and visually inspect for defects or other problems. You should have a solder joint with a bright shiny finish and a profile like that shown in the middle picture below.

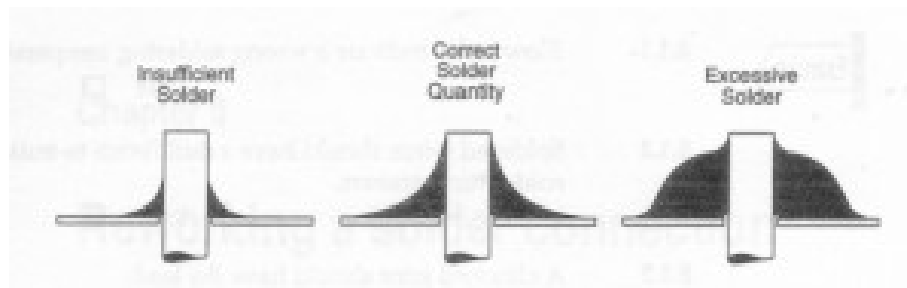

Figure C4 - Solder quantity comparison